

PennEngineering®

SELF-CLINCHING STANDOFFS

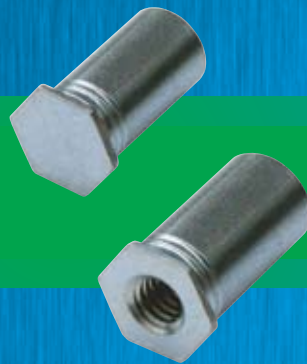

BULLETIN **SO**



SELF-CLINCHING STANDOFFS

These standoffs, which use the proven self-clinching design, install with a squeeze in properly sized round holes – and become permanently mounted in the thin sheet.

PEM® brand thru-hole threaded standoffs (**Page 3**) are installed with their heads flush with one surface of the mounting sheet. When blind-threaded types (**Page 4**) are used, outer sheet surfaces are not only flush, but closed as well. Unthreaded standoffs (**Page 5**) are also available for spacing multi-panel assemblies.

Types SO4 and BSO4 standoffs (**Pages 6 and 7**) are for installation into stainless steel sheets as thin as .040" / 1.02 mm.

Types TSO, TSOS, and TSOA self-clinching threaded standoffs (**Page 8**) provide permanent threads in sheets as thin as .025" / 0.63 mm.

PEM® self-clinching standoffs are also available on special order in non-heat treated carbon steel as type SON (thru-hole threaded) or BSON (blind threaded).

Types DSO and DSOS standoffs (**Page 9**) are available for close-to-edge applications.

If you require a standoff which we do not offer in this bulletin, please contact us. We will be happy to work with you to satisfy your special need. For other types of PEM® brand standoffs and spacers see:

Bulletin CH	PEM® Concealed-head Standoffs.
Bulletin K	PEM® Standoffs for printed circuit boards.
Bulletin SK	PEM® KEYHOLE® Standoffs.
Bulletin SMT	PEM® ReelFast® SMT Spacers/Nuts.
Bulletin SSA	PEM® brand SNAP-TOP® Standoffs.

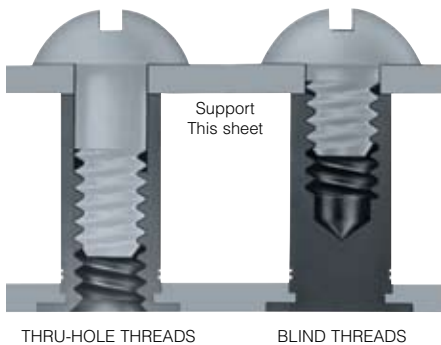

Always look for the "One or Two Groove" trademarks to be sure you are getting genuine PEM® brand standoffs. On actual parts, location of grooves on barrel may be different than shown in photo.



SELF-CLINCHING STANDOFFS

TYPES SO, SOA, AND SOS THRU-HOLE THREADED STANDOFFS

GENERAL DIMENSIONAL DATA

All dimensions are in inches.

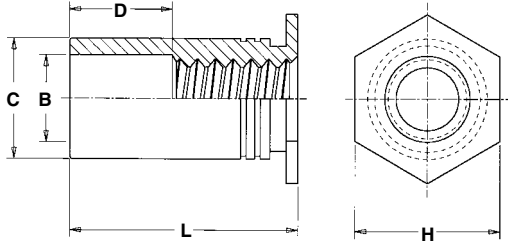

UNIFIED	Thread Code	Min. Sheet Thickness	Hole Size In Sheet +.003 -.000	B Counter-Bore Dia. ±.005	C +.000 -.005	H Nom.	Min. Dist. Hole \varnothing To Edge
	440	.040	.166	.125	.165	.187	.23
6440	.040	.213	.125	.212	.250	.27	
632	.040	.213	.156	.212	.250	.27	
8632	.050	.281	.156	.280	.312	.31	
832	.050	.281	.188	.280	.312	.31	
032	.050	.281	.203	.280	.312	.31	

All dimensions are in millimeters.

METRIC	Thread Code	Min. Sheet Thickness	Hole Size In Sheet +0.08	B Counter-Bore Dia. ±0.13	C -0.13	H Nom.	Min. Dist. Hole \varnothing To Edge
	M3	1.02	4.22	3.2	4.2	4.8	6
3.5M3	1.02	5.41	3.2	5.39	6.4	6.8	
M3.5	1.02	5.41	3.9	5.39	6.4	6.8	
M4	1.27	7.14	4.8	7.12	7.9	8	
M5	1.27	7.14	5.35	7.12	7.9	8	

PART NUMBER DESIGNATION



SO **S** - **440** - **8** **ZI**

Type Material Code Thread Size Code Length Code Finish

THREAD SIZE AND LENGTH SELECTION DATA

All dimensions are in inches.

UNIFIED	Thread Size	Type			Thread Code	Length "L" +.002 - .005 (Length Code in 32nds of an inch)														
		Steel	Stainless Steel	Aluminum		.125	.187	.250	.312	.375	.437	.500	.562	.625	.687	.750	.812	.875	.937	1.00
.112-40 (#4-40)	SO	SOS	SOA	440	4	6	8	10	12	14	16	18	20	22	24	N/A	N/A	N/A	N/A	N/A
				6440 ⁽¹⁾																
.138-32 (#6-32)	SO	SOS	SOA	632	4	6	8	10	12	14	16	18	20	22	24	26	28	30	32	34
				8632 ⁽¹⁾																
.164-32 (#8-32)	SO	SOS	SOA	832	4	6	8	10	12	14	16	18	20	22	24	26	28	30	32	34
.190-32 (#10-32)	SO	SOS	SOA	032	4	6	8	10	12	14	16	18	20	22	24	26	28	30	32	34
D Dimension ±.010					None				.187				.312				.437			

All dimensions are in millimeters.

METRIC	Thread Size x Pitch	Type			Thread Code	Length "L" +0.05 -0.13 (Length Code in millimeters)														
		Steel	Stainless Steel	Aluminum		3	4	6	8	10	12	14	16	18	20	22	25			
M3 x 0.5	SO	SOS	SOA	M3	3	4	6	8	10	12	14	16	18	N/A	N/A	N/A				
				3.5M3 ⁽¹⁾																
M3.5 x 0.6	SO	SOS	SOA	M3.5	3	4	6	8	10	12	14	16	18	20	22	25				
M4 x 0.7	SO	SOS	SOA	M4	3	4	6	8	10	12	14	16	18	20	22	25				
M5 x 0.8	SO	SOS	SOA	M5	3	4	6	8	10	12	14	16	18	20	22	25				
D Dimension ±0.25					None				4				8				11			

(1) Standoffs with thread codes 6440, 8632, and 3.5M3 offer greater wall thickness for thread sizes #4-40, #6-32, and M3 respectively.
N/A - Not Available.

Please contact your local PEM® distributor for availability, minimum quantity, and pricing information.

SELF-CLINCHING STANDOFFS

TYPES BSO, BSOA, AND BSOS BLIND THREADED STANDOFFS

GENERAL DIMENSIONAL DATA

All dimensions are in inches.

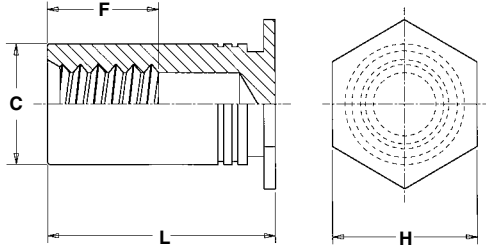

UNIFIED	Thread Code	Min. Sheet Thickness	Hole Size In Sheet +.003 -.000	C +.000 -.005	H Nom.	Min. Dist. Hole \varnothing To Edge
	440	.040	.166	.165	.187	.23
	6440	.040	.213	.212	.250	.27
	632	.040	.213	.212	.250	.27
	8632	.050	.281	.280	.312	.31
	832	.050	.281	.280	.312	.31
	032	.050	.281	.280	.312	.31

All dimensions are in millimeters.

METRIC	Thread Code	Min. Sheet Thickness	Hole Size In Sheet +0.08	C -0.13	H Nom.	Min. Dist. Hole \varnothing To Edge
	M3	1.02	4.22	4.2	4.8	6
	3.5M3	1.02	5.41	5.39	6.4	6.8
	M3.5	1.02	5.41	5.39	6.4	6.8
	M4	1.27	7.14	7.12	7.9	8
	M5	1.27	7.14	7.12	7.9	8

PART NUMBER DESIGNATION

BSO S - 440 - 8 ZI

Type Material Code Thread Size Code Length Code Finish



THREAD SIZE AND LENGTH SELECTION DATA

All dimensions are in inches.

UNIFIED	Thread Size Steel	Type			Thread Code	Length "L" +.002 -.005 (Length Code in 32nds of an inch)												
		Steel	Stainless	Aluminum		.312	.375	.437	.500	.562	.625	.687	.750	.812	.875	.937	1.00	1.062
		.112-40 (#4-40)	BSO	BSOS		BSOA	440 6440 ⁽¹⁾	10	12	14	16	18	20	22	24	26	28	30
.138-32 (#6-32)	BSO	BSOS	BSOA	632 8632 ⁽¹⁾	10	12	14	16	18	20	22	24	26	28	30	32	34	
.164-32 (#8-32)	BSO	BSOS	BSOA	832	10	12	14	16	18	20	22	24	26	28	30	32	34	
.190-32 (#10-32)	BSO	BSOS	BSOA	032	10	12	14	16	18	20	22	24	26	28	30	32	34	
F Dimension Min.					.156	.187	.250				.375							

All dimensions are in millimeters.

METRIC	Thread Size x Pitch	Type			Thread Code	Length "L" +0.05 -0.13 (Length Code in millimeters)										
		Steel	Stainless Steel	Aluminum		6	8	10	12	14	16	18	20	22	25	
		M3 x 0.5	BSO	BSOS		BSOA	M3 3.5M3 ⁽¹⁾	6	8	10	12	14	16	18	20	22
M3.5 x 0.6	BSO	BSOS	BSOA	M3.5	6	8	10	12	14	16	18	20	22	25		
M4 x 0.7	BSO	BSOS	BSOA	M4	6	8	10	12	14	16	18	20	22	25		
M5 x 0.8	BSO	BSOS	BSOA	M5	6	8	10	12	14	16	18	20	22	25		
F Dimension Min.					3.2	4	5	6.5			9.5					

(1) Standoffs with thread codes 6440, 8632, and 3.5M3 offer greater wall thickness for thread sizes #4-40, #6-32, and M3 respectively.

Please contact your local PEM® distributor for availability, minimum quantity, and pricing information.

SELF-CLINCHING STANDOFFS

TYPES SO, SOA, AND SOS THRU-HOLE UNTHREADED STANDOFFS

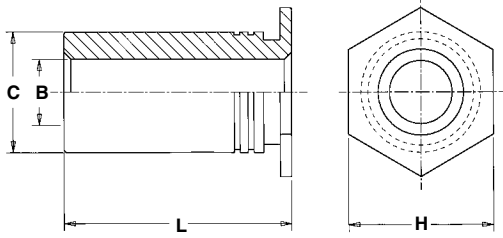

GENERAL DIMENSIONAL DATA

All dimensions are in inches.

UNIFIED	Thru-hole Code	Min. Sheet Thickness	Hole Size In Sheet +.003 -.000	C +.000 -.005	H Nom.	Min. Dist. Hole \varnothing To Edge
	4116	.040	.166	.165	.187	.23
	6116	.040	.213	.212	.250	.27
	6143	.040	.213	.212	.250	.27
	8143	.050	.281	.280	.312	.31
	8169	.050	.281	.280	.312	.31
	8194	.050	.281	.280	.312	.31

All dimensions are in millimeters.

METRIC	Thru-hole Code	Min. Sheet Thickness	Hole Size In Sheet +0.08	C -0.13	H Nom.	Min. Dist. Hole \varnothing To Edge
	43.1	1.02	4.22	4.2	4.8	6
	63.1	1.02	5.41	5.39	6.4	6.8
	63.6	1.02	5.41	5.39	6.4	6.8
	83.6	1.27	7.14	7.12	7.9	8
	84.1	1.27	7.14	7.12	7.9	8
	85.1	1.27	7.14	7.12	7.9	8

PART NUMBER DESIGNATION

SO S - 4116 - 8 ZI

↓ ↓ ↓ ↓ ↓

Type Material Code Thru-hole Code Length Code Finish



PEM® thru-hole, unthreaded standoffs are available on special order only.

THRU-HOLE AND LENGTH SELECTION DATA

All dimensions are in inches.

UNIFIED	B Thru-hole Diameter +.004 -.003	Type			Thru-hole Code	Length "L" +.002 -.005 (Length Code in 32nds of an inch)										
		Steel	Stainless Steel	Aluminum		.125	.187	.250	.312	.375	.437	.500	.562	.625	.687	.750
	.116	SO	SOS	SOA	4116 6116 ⁽¹⁾	4	6	8	10	12	14	16	18	20	22	24
.143	SO	SOS	SOA	6143 8143 ⁽¹⁾	4	6	8	10	12	14	16	18	20	22	24	
.169	SO	SOS	SOA	8169	4	6	8	10	12	14	16	18	20	22	24	
.194	SO	SOS	SOA	8194	4	6	8	10	12	14	16	18	20	22	24	

All dimensions are in millimeters.

METRIC	B Thru-hole Diameter +0.1 -0.08	Type			Thru-hole Code	Length "L" +0.05 -0.13 (Length Code in millimeters)										
		Steel	Stainless Steel	Aluminum		3	4	6	8	10	12	14	16	18	20	
	3.1	SO	SOS	SOA	43.1 63.1 ⁽¹⁾	3	4	6	8	10	12	14	16	18	20	
3.6	SO	SOS	SOA	63.6 83.6 ⁽¹⁾	3	4	6	8	10	12	14	16	18	20		
4.1	SO	SOS	SOA	84.1	3	4	6	8	10	12	14	16	18	20		
5.1	SO	SOS	SOA	85.1	3	4	6	8	10	12	14	16	18	20		

(1) Standoffs with thru-hole codes 6116, 8143, 63.1 and 83.6 offer greater wall thickness for that thru-hole diameter.

Please contact your local PEM® distributor for availability, minimum quantity, and pricing information.

SELF-CLINCHING STANDOFFS

TYPE SO4 THRU-HOLE THREADED STANDOFFS FOR INSTALLATION INTO STAINLESS STEEL SHEETS

GENERAL DIMENSIONAL DATA

All dimensions are in inches.

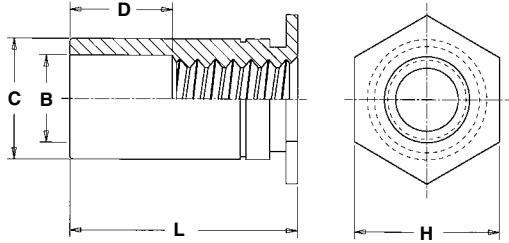

UNIFIED	Thread Code	Min. Sheet Thickness	Hole Size In Sheet +.003 -.000	B Counter-Bore Dia. ±.005	C +.000 -.005	H Nom.	Min. Dist. Hole \varnothing To Edge
	440	.040	.166	.125	.165	.187	.23
	6440	.040	.213	.125	.212	.250	.28
	632	.040	.213	.156	.212	.250	.28
	8632	.050	.281	.156	.280	.312	.33
	832	.050	.281	.188	.280	.312	.33
	032	.050	.281	.203	.280	.312	.33

All dimensions are in millimeters.

METRIC	Thread Code	Min. Sheet Thickness	Hole Size In Sheet +0.08	B Counter-Bore Dia. ±0.13	C -0.13	H Nom.	Min. Dist. Hole \varnothing To Edge
	M3	1.02	4.22	3.25	4.2	4.8	6
	3.5M3	1.02	5.41	3.25	5.39	6.4	7.1
	M3.5	1.02	5.41	3.9	5.39	6.4	7.1
	M4	1.27	7.14	4.8	7.12	7.9	8.4
	M5	1.27	7.14	5.35	7.12	7.9	8.4

PART NUMBER DESIGNATION



SO **4** - **440** - **8**

Type Material Code Thread Size Code Length Code

THREAD SIZE AND LENGTH SELECTION DATA

All dimensions are in inches.

UNIFIED	Thread Size	Type	Thread Code	Length "L" +.002 -.005 (Length Code in 32nds of an inch)															
				.125	.187	.250	.312	.375	.437	.500	.562	.625	.687	.750	.812	.875	.937	1.00	1.062
	.112-40 (#4-40)	SO4	440	4	6	8	10	12	14	16	18	20	22	24	N/A	N/A	N/A	N/A	N/A
			6440 ⁽¹⁾	4	6	8	10	12	14	16	18	20	22	24	26	28	30	32	34
	.138-32 (#6-32)	SO4	632	4	6	8	10	12	14	16	18	20	22	24	26	28	30	32	34
			8632 ⁽¹⁾	4	6	8	10	12	14	16	18	20	22	24	26	28	30	32	34
	.164-32 (#8-32)	SO4	832	4	6	8	10	12	14	16	18	20	22	24	26	28	30	32	34
	.190-32 (#10-32)	SO4	032	4	6	8	10	12	14	16	18	20	22	24	26	28	30	32	34
D Dimension ±.010				None				.187				.312				.437			

All dimensions are in millimeters.

METRIC	Thread Size x Pitch	Type	Thread Code	Length "L" +0.05 -0.13 (Length Code in millimeters)															
				3	4	6	8	10	12	14	16	18	20	22	25				
	M3 x 0.5	SO4	M3	3	4	6	8	10	12	14	16	18	N/A	N/A	N/A				
			3.5M3 ⁽¹⁾	3	4	6	8	10	12	14	16	18	20	22	25				
	M3.5 x 0.6	SO4	M3.5	3	4	6	8	10	12	14	16	18	20	22	25				
	M4 x 0.7	SO4	M4	3	4	6	8	10	12	14	16	18	20	22	25				
	M5 x 0.8	SO4	M5	3	4	6	8	10	12	14	16	18	20	22	25				
D Dimension ±0.25				None				4				8				11			

(1) Standoffs with thread codes 6440, 8632, and 3.5M3 offer greater wall thickness for thread sizes #4-40, #6-32, and M3 respectively.
N/A Not Available.

Please contact your local PEM® distributor for availability, minimum quantity, and pricing information.

SELF-CLINCHING STANDOFFS

TYPE BSO4 BLIND THREADED STANDOFFS FOR INSTALLATION INTO STAINLESS STEEL SHEETS

GENERAL DIMENSIONAL DATA

All dimensions are in inches.

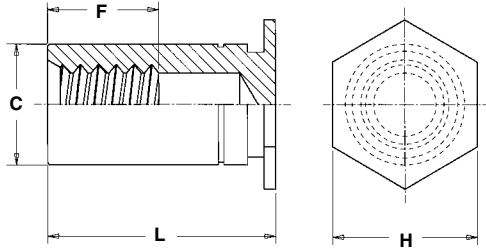

UNIFIED	Thread Code	Min. Sheet Thickness	Hole Size In Sheet +.003 -.000	C +.000 -.005	H Nom.	Min. Dist. Hole \varnothing To Edge
	440	.040	.166	.165	.187	.23
	6440	.040	.213	.212	.250	.28
	632	.040	.213	.212	.250	.28
	8632	.050	.281	.280	.312	.33
	832	.050	.281	.280	.312	.33
	032	.050	.281	.280	.312	.33

All dimensions are in millimeters.

METRIC	Thread Code	Min. Sheet Thickness	Hole Size In Sheet +0.08	C -0.13	H Nom.	Min. Dist. Hole \varnothing To Edge
	M3	1.02	4.22	4.2	4.8	6
	3.5M3	1.02	5.41	5.39	6.4	7.1
	M3.5	1.02	5.41	5.39	6.4	7.1
	M4	1.27	7.14	7.12	7.9	8.4
	M5	1.27	7.14	7.12	7.9	8.4

PART NUMBER DESIGNATION



BSO 4 - 440 - 8

Type Material Code Thread Size Code Length Code

THREAD SIZE AND LENGTH SELECTION DATA

All dimensions are in inches.

UNIFIED	Thread Size	Type	Thread Code	Length "L" +.002 - .005 (Length Code in 32nds of an inch)												
				.312	.375	.437	.500	.562	.625	.687	.750	.812	.875	.937	1.00	1.062
	.112-40 (#4-40)	BS04	440	10	12	14	16	18	20	22	24	26	28	30	32	34
			6440 ⁽¹⁾	10	12	14	16	18	20	22	24	26	28	30	32	34
	.138-32 (#6-32)	BS04	632	10	12	14	16	18	20	22	24	26	28	30	32	34
			8632 ⁽¹⁾	10	12	14	16	18	20	22	24	26	28	30	32	34
	.164-32 (#8-32)	BS04	832	10	12	14	16	18	20	22	24	26	28	30	32	34
	.190-32 (#10-32)	BS04	032	10	12	14	16	18	20	22	24	26	28	30	32	34
F Dimension Min.				.156		.187		.250			.375					

All dimensions are in millimeters.

METRIC	Thread Size x Pitch	Type	Thread Code	Length "L" +0.05 -0.13 (Length Code in millimeters)									
				6	8	10	12	14	16	18	20	22	25
	M3 x 0.5	BS04	M3	6	8	10	12	14	16	18	20	22	25
			3.5M3 ⁽¹⁾	6	8	10	12	14	16	18	20	22	25
	M3.5 x 0.6	BS04	M3.5	6	8	10	12	14	16	18	20	22	25
	M4 x 0.7	BS04	M4	6	8	10	12	14	16	18	20	22	25
	M5 x 0.8	BS04	M5	6	8	10	12	14	16	18	20	22	25
F Dimension Min.				3.2	4		5	6.5			9.5		

(1) Standoffs with thread codes 6440, 8632, and 3.5M3 offer greater wall thickness for thread sizes #4-40, #6-32, and M3 respectively.

Please contact your local PEM® distributor for availability, minimum quantity, and pricing information.

SELF-CLINCHING STANDOFFS

TYPES TSO, TSOA AND TSOS THREADED STANDOFFS FOR SHEETS AS THIN AS .025"/0.63mm

GENERAL DIMENSIONAL DATA

All dimensions are in inches.

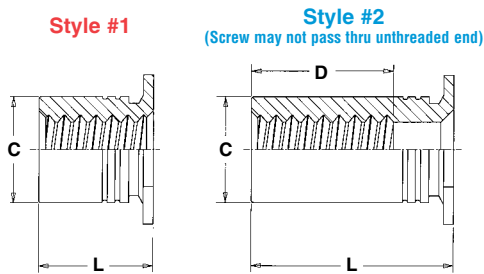

UNIFIED	Thread Code	Min. Sheet Thickness	Hole Size In Sheet +.003 -.000	C +.000 -.005	D Min. Thread Depth	H Nom.	Min. Dist. Hole ϕ To Edge
	256	.025	.166	.165	.200	.187	.23
6256	.025	.213	.212	.250		.27	
440	.025	.166	.165	.220	.187	.23	
6440	.025	.213	.212		.250	.27	
632	.025	.213	.212		.250	.27	

All dimensions are in millimeters.

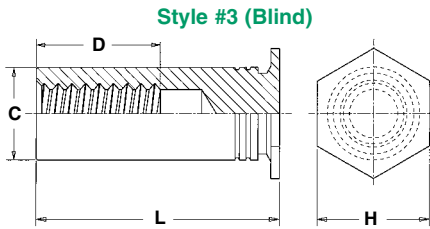

METRIC	Thread Code	Min. Sheet Thickness	Hole Size In Sheet +0.08	C -0.13	D Min. Thread Depth	H Nom.	Min. Dist. Hole ϕ To Edge
	M25	0.63	4.22	4.2	5.2	4.8	5.8
6M25	0.63	5.41	5.39	6.4		7.1	
M3	0.63	4.22	4.2	6.2	4.8	5.8	
6M3	0.63	5.41	5.39		6.4	7.1	
M35	0.63	5.41	5.39		7	6.4	7.1

THREAD SIZE AND LENGTH SELECTION DATA

All dimensions are in inches.

UNIFIED	Thread Size	Type			Thread Code	Length "L" \pm .003											
		Steel	Stainless Steel	Aluminum		For other lengths / thread depth data see chart below.											
						.090	.125	.187	.250	.312	.375	.437	.500	.562	.625	.687	.750
						Length Code (Length "L" without decimal point)											
.086-56 (#2-56)	TSO	TSOS	TSOA	256	090(1)	125(1)	187(1)	250(1)	312(2)	375(2)	437(3)	500(3)	562(3)	625(3)	687(3)	750(3)	
					6256(4)												
.112-40 (#4-40)	TSO	TSOS	TSOA	440	090(1)	125(1)	187(1)	250(1)	312(2)	375(2)	437(2)	500(3)	562(3)	625(3)	687(3)	750(3)	
					6440(4)												
.138-32 (#6-32)	TSO	TSOS	TSOA	632	N/A	125(1)	187(1)	250(1)	312(1)	375(2)	437(2)	500(2)	562(3)	625(3)	687(3)	750(3)	

All dimensions are in millimeters.

METRIC	Thread Size x Pitch	Type			Thread Code	Length "L" \pm 0.08											
		Steel	Stainless Steel	Aluminum		For other lengths / thread depth data see chart below.											
						2.00	3.00	4.00	6.00	8.00	10.00	12.00	14.00	16.00	18.00	19.00	
						Length Code (Length "L" without decimal point)											
M2.5 x 0.45	TSO	TSOS	TSOA	M25	200(1)	300(1)	400(1)	600(1)	800(2)	1000(3)	1200(3)	1400(3)	1600(3)	1800(3)	1900(3)		
				6M25(4)													
M3 x 0.5	TSO	TSOS	TSOA	M3	200(1)	300(1)	400(1)	600(1)	800(2)	1000(2)	1200(3)	1400(3)	1600(3)	1800(3)	1900(3)		
				6M3(4)													
M3.5 x 0.6	TSO	TSOS	TSOA	M35	N/A	300(1)	400(1)	600(1)	800(1)	1000(2)	1200(2)	1400(3)	1600(3)	1800(3)	1900(3)		

(1) Style #1.

(2) Style #2.

(3) Style #3.

(N/A) Not Available

(4) Standoffs with thread codes 6256, 6440, 6M25 and 6M3 offer greater wall thickness for thread sizes #2-56, #4-40, M2.5 and M3 respectively. Please contact your local PEM® distributor for availability, minimum quantity, and pricing information.

LENGTH/STYLE DATA

All dimensions are in inches.

(Length can be specified in .001" increments.)

UNIFIED	Thread Code	Length "L" (Style #1)	Length "L" (Style #2)	Length "L" (Style #3)
	256 6256	.090 - .250	.251 - .375	.376 - .750
440 6440	.090 - .280	.281 - .450	.451 - .750	
632	.120 - .350	.351 - .540	.541 - .750	

All dimensions are in millimeters.

(Length can be specified in .02mm increments.)

METRIC	Thread Code	Length "L" (Style #1)	Length "L" (Style #2)	Length "L" (Style #3)
	M25 6M25	2.00 - 6.30	6.32 - 9.50	9.52 - 19.00
M3 6M3	2.00 - 7.50	7.52 - 11.00	11.02 - 19.00	
M35	3.00 - 8.80	8.82 - 12.80	12.82 - 19.00	

PART NUMBER DESIGNATION

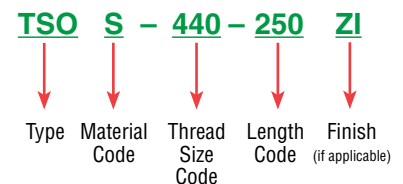

SELF-CLINCHING STANDOFFS

TYPES DSO AND DSOS THREADED STANDOFFS FOR CLOSE-TO-EDGE APPLICATIONS

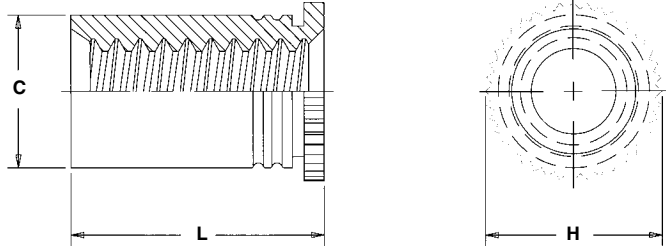
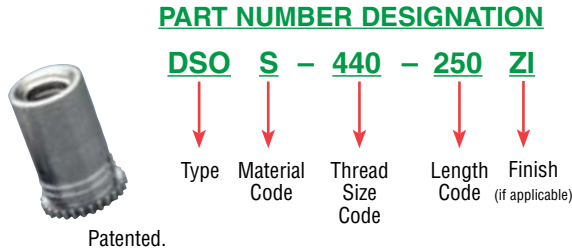

All dimensions are in inches.

UNIFIED	Thread Size (#4-40)	Type		Thread Code	Length Code	Sheet Thickness	Hole Size in Sheet +.003 -.000	C Max.	H Nom.	L ⁽¹⁾ +.002 -.005	Min. Dist. Hole \varnothing To Edge
		Stainless Steel	Steel								
		DSOS	DSO	440	250	.037 - .250	.166	.165	.194	.250	.126
					275					.275	

All dimensions are in millimeters.

METRIC	Thread Size x Pitch M3 x 0.5	Type		Thread Code	Length Code	Sheet Thickness	Hole Size in Sheet +0.08	C Max.	H Nom.	L ⁽¹⁾ +0.05 -0.13	Min. Dist. Hole \varnothing To Edge
		Stainless Steel	Steel								
		DSOS	DSO	M3	6.35	0.94 - 6.35	4.22	4.2	4.92	6.35	3.2
					7					7	

(1) Available in other lengths on special order.

Please contact your local PEM® distributor for availability, minimum quantity, and pricing information.

MATERIAL AND FINISH SPECIFICATIONS

Type	Threads ⁽¹⁾	Fastener Materials					Standard Finishes			For Use In Sheet Hardness: ⁽³⁾				
	Internal, ANSI B1.1 2B ANSI/ASME B1.13M, 6H	Heat-treated Carbon Steel	Non-heat Treated Carbon Steel	Aluminum	300 Series Stainless Steel	400 Series Stainless Steel	Zinc Plated 5µm, Colorless ⁽²⁾	Passivated and/or Tested Per ASTM A380	No Finish	HRB 88 / HB 176 or Less	HRB 80 / HB 150 or Less	HRB 70 / HB 125 or Less	HRB 60 / HB 107 or Less	HRB 50 / HB 82 or Less
SO	•	•					•							
SOA	•			•				•						•
SOS	•				•			•			•			
SO4	•					•		•						
BSO	•	•					•				•			
BSOA	•			•				•						•
BSOS	•				•			•			•			
BSO4	•					•		•						
TSO	•		•				•					•		
TSOS	•				•			•			•			
TSOA	•			•				•						•
DSO	•	•					•				•			
DSOS	•				•			•			•			
Part Number Codes For Finishes							ZI	None	None					

(1) Where applicable.

(2) See PEM Technical Support section of our web site for related plating standards and specifications.

(3) HRB - Hardness Rockwell "B" Scale. HB - Hardness Brinell.

SELF-CLINCHING STANDOFFS

INSTALLATION

TYPES SO, SOA, SOS, SO4, BSO, BSOA, BSOS AND BSO4

1. Prepare properly sized mounting hole in sheet. Do not perform any secondary operation such as deburring.
2. Insert standoff through mounting hole of sheet and into anvil as shown in drawing.
3. With punch and anvil surfaces parallel, apply only enough squeezing force to embed the standoff's head flush in the sheet. Drawing at right shows suggested tooling for applying these forces.

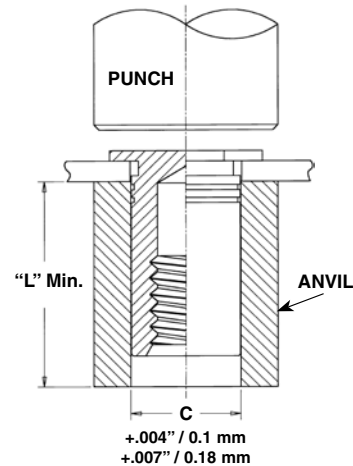

TYPES TSO, TSOA AND TSOS

1. Prepare properly sized mounting hole in sheet. Do not perform any secondary operation such as deburring.
2. Insert standoff through mounting hole of sheet and into anvil as shown in drawing.
3. With punch and anvil surfaces parallel, apply only enough squeezing force to embed the standoff's head flush in the sheet. Drawing at right shows required installation anvil for sheet thickness of .025\"/>

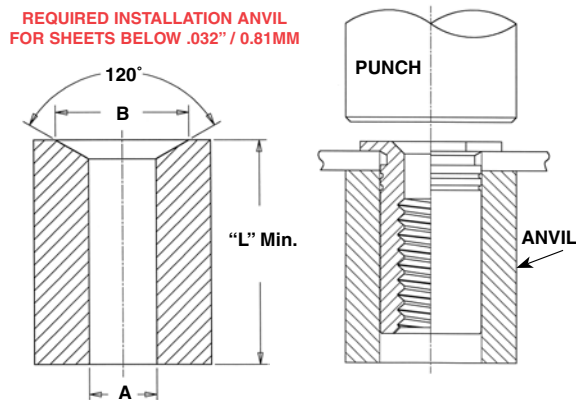

All dimensions are in inches.

Standoff "C" Dimensions	Anvil Dimensions	
	A	B
.165	.167 - .170	.187 - .194
.212	.213 - .216	.250 - .257

All dimensions are in millimeters.

Standoff "C" Dimensions	Anvil Dimensions	
	A	B
4.19	4.24 - 4.32	4.75 - 4.93
5.39	5.41 - 5.49	6.35 - 6.53

TYPES DSO AND DSOS

1. Prepare properly sized mounting hole in sheet. Do not perform any secondary operations such as deburring.
2. Insert fastener through mounting hole and into anvil as shown in drawing.
3. With punch and anvil surfaces parallel, apply only enough squeezing force to embed the standoff's head flush in the sheet.

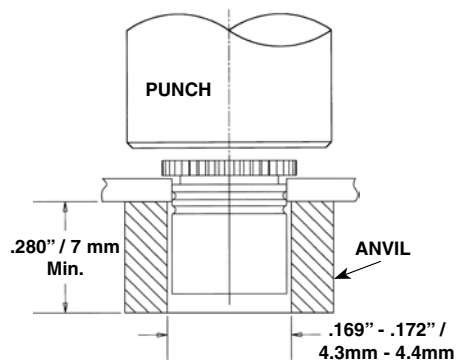

PEMSERTER® PRESSES

For best results we recommend using a PEMSERTER® press for either manual or automatic installation of PEM standoffs. For more information on our line of presses call 1-800-523-5321, or check our web site.

SELF-CLINCHING STANDOFFS

PERFORMANCE DATA⁽¹⁾

TYPES SO, SOA, SOS, BSO, BSOA AND BSOS

UNIFIED	Thread Code	Standoff Material	Max. Rec. Tightening Torque For Mating Screw (in. lbs.)	Test Sheet Material							
				.060" 5052-H34 Aluminum ⁽²⁾				.060" Cold-rolled Steel ⁽²⁾			
				Installation (lbs.)	Pushout (lbs.)	Torque-out (in. lbs.)	Pull-thru (lbs.)	Installation (lbs.)	Pushout (lbs.)	Torque-out (in. lbs.)	Pull-thru (lbs.)
440	Steel	4.75	1100	160	11	280	2200	225	19	330	
	Stainless Steel	3.8	1100	160	11	224	2200	225	19	264	
	Aluminum	2.85	1100	160	11	168	(3)	(3)	(3)	(3)	
6440	Steel	4.75	1700	300	11	280	3300	420	19	330	
	Stainless Steel	3.8	1700	300	11	224	3300	420	19	264	
	Aluminum	2.85	1700	300	11	168	(3)	(3)	(3)	(3)	
632	Steel	8.75	1700	300	25	310	3300	420	35	380	
	Stainless Steel	7	1700	300	25	248	3300	420	35	304	
	Aluminum	5.25	1700	300	25	186	(3)	(3)	(3)	(3)	
8632	Steel	8.75	2400	400	25	310	4000	560	35	380	
	Stainless Steel	7	2400	400	25	248	4000	560	35	304	
	Aluminum	5.25	2400	400	25	186	(3)	(3)	(3)	(3)	
832, 032	Steel	18, 32	2400	400	45	580	4000	560	75	700	
	Stainless Steel	14.4, 25.6	2400	400	45	464	4000	560	75	560	
	Aluminum	11, 19	2400	400	45	348	(3)	(3)	(3)	(3)	

METRIC	Thread Code	Standoff Material	Max. Rec. Tightening Torque For Mating Screw (N•m)	Test Sheet Material							
				1.5 mm 5052-H34 Aluminum ⁽²⁾				1.5 mm Cold-rolled Steel ⁽²⁾			
				Installation (kN)	Pushout (N)	Torque-out (N•m)	Pull-thru (N)	Installation (kN)	Pushout (N)	Torque-out (N•m)	Pull-thru (N)
M3	Steel	0.55	4.9	710	1.24	1245	9.8	1000	2.15	1465	
	Stainless Steel	0.44	4.9	710	1.24	996	9.8	1000	2.15	1172	
	Aluminum	0.33	4.9	710	1.24	747	(3)	(3)	(3)	(3)	
3.5M3	Steel	0.55	7.6	1330	1.24	1245	14.7	1860	2.15	1465	
	Stainless Steel	0.44	7.6	1330	1.24	996	14.7	1860	2.15	1172	
	Aluminum	0.33	7.6	1330	1.24	747	(3)	(3)	(3)	(3)	
M3.5	Steel	0.91	7.6	1330	2.82	1375	14.7	1860	3.95	1690	
	Stainless Steel	0.73	7.6	1330	2.82	1100	14.7	1860	3.95	1352	
	Aluminum	0.55	7.6	1330	2.82	825	(3)	(3)	(3)	(3)	
M4, M5	Steel	2, 3.6	10.7	1780	5.08	2575	17.8	2490	8.47	3110	
	Stainless Steel	1.6, 2.88	10.7	1780	5.08	2060	17.8	2490	8.47	2488	
	Aluminum	1.2, 2.16	10.7	1780	5.08	1545	(3)	(3)	(3)	(3)	

TYPES SO4 AND BSO4

UNIFIED	Thread Code	Max. Rec. Tightening Torque For Mating Screw (in. lbs.)	Test Sheet Material			
			.050" 300 Series Stainless Steel			
			Installation (lbs.)	Pushout (lbs.)	Torque-out (in. lbs.)	Pull-thru (lbs.)
440	4.75	5500	336	17	600	
6440	4.75	9500	647	17	680	
632	8.75	9500	647	30	680	
8632	8.75	10500	900	30	1392	
832	18	10500	900	53	1517	
032	32	10500	900	71	1368	

METRIC	Thread Code	Max. Rec. Tightening Torque For Mating Screw (N•m)	Test Sheet Material			
			1.3 mm 300 Series Stainless Steel			
			Installation (kN)	Pushout (N)	Torque-out (N•m)	Pull-thru (N)
M3	0.55	24.5	1493	2.36	2650	
3.5M3	0.55	42.3	2877	2.36	3025	
M3.5	0.91	42.3	2877	3.06	3025	
M4	2	46.7	4003	6.34	6458	
M5	3.6	46.7	4003	8.89	6226	

TYPES TSO, TSOA AND TSOS

Standoff "C" Dimension	Standoff Material	Test Sheet Material											
		.025" / 0.64 mm 5052-H34 Aluminum					.025" / 0.64 mm Cold-rolled Steel						
		Installation (lbs.)	Pushout (kN)	Pushout (lbs.)	Torque-out (N)	Torque-out (in. lbs.)	Torque-out (N•m)	Installation (lbs.)	Pushout (kN)	Pushout (lbs.)	Torque-out (N)	Torque-out (in. lbs.)	Torque-out (N•m)
.165" / 4.19 mm	Steel	1500	6.7	70	311	6	0.68	2000	8.9	100	445	9	1
	Stainless Steel	1500	6.7	70	311	6	0.68	2000	8.9	100	445	9	1
	Aluminum	1500	6.7	70	311	6	0.68	—	—	—	—	—	—
.212" / 5.38 mm	Steel	1800	8	90	400	11	1.24	2500	11.1	150	667	15	1.7
	Stainless Steel	1800	8	90	400	11	1.24	2500	11.1	150	667	15	1.7
	Aluminum	1800	8	90	400	11	1.24	—	—	—	—	—	—

(1) The values reported are averages when all installation specifications and procedures are followed. Variations in mounting hole size, sheet material and installation procedure will affect this data. Performance testing of this product in your application is recommended. We will be happy to provide samples for this purpose.

(2) Standoffs installed in sheets thinner than .060"/1.5mm and greater than the specified minimum sheet thickness will have pull-thru, pushout, and torque-out values approximately 80% of tabulated values.

(3) Not recommended.

SELF-CLINCHING STANDOFFS

PERFORMANCE DATA⁽¹⁾

TYPES DSO AND DSOS

UNIFIED	Thread Code	Max. Rec. Tightening Torque For Mating Screw (in. lbs.)	Test Sheet Material					
			.040" 5052-H34 Aluminum			.040" Cold-rolled Steel		
			Installation (lbs.)	Pushout (lbs.)	Torque-out (in. lbs.)	Installation (lbs.)	Pushout (lbs.)	Torque-out (in. lbs.)
	440	3.8	1000	50	10	1300	75	10

METRIC	Thread Code	Max. Rec. Tightening Torque For Mating Screw (N•m)	Test Sheet Material					
			1 mm 5052-H34 Aluminum			1 mm Cold-rolled Steel		
			Installation (kN)	Pushout (N)	Torque-out (N•m)	Installation (kN)	Pushout (N)	Torque-out (N•m)
	M3	0.44	4.5	223	1.1	5.8	334	1.1

(1) The values reported are averages when all installation specifications and procedures are followed. Variations in mounting hole size, sheet material and installation procedure will affect this data. Performance testing of this product in your application is recommended. We will be happy to provide samples for this purpose.

RoHS compliance information can be found on our website.
© 2009 PennEngineering.

Specifications subject to change without notice.
Check our website for the most current version of this bulletin.

PennEngineering®



North America: Danboro, PA USA • E-mail: info@pemnet.com • Tel: +1-215-766-8853 • Fax: +1-215-766-0143 • 800-237-4736 (USA Only)
Europe: Galway, Ireland • E-mail: europe@pemnet.com • Tel: +353-91-751714 • Fax: +353-91-753541
Asia/Pacific: Singapore • E-mail: singapore@pemnet.com • Tel: +65-6-745-0660 • Fax: +65-6-745-2400
 Shanghai, China • E-mail: china@pemnet.com • Tel: +86-21-5868-3688 • Fax: +86-21-5868-3988

Visit our PEMNET™ Resource Center at www.pemnet.com